

EJERCITADOR CINTURA

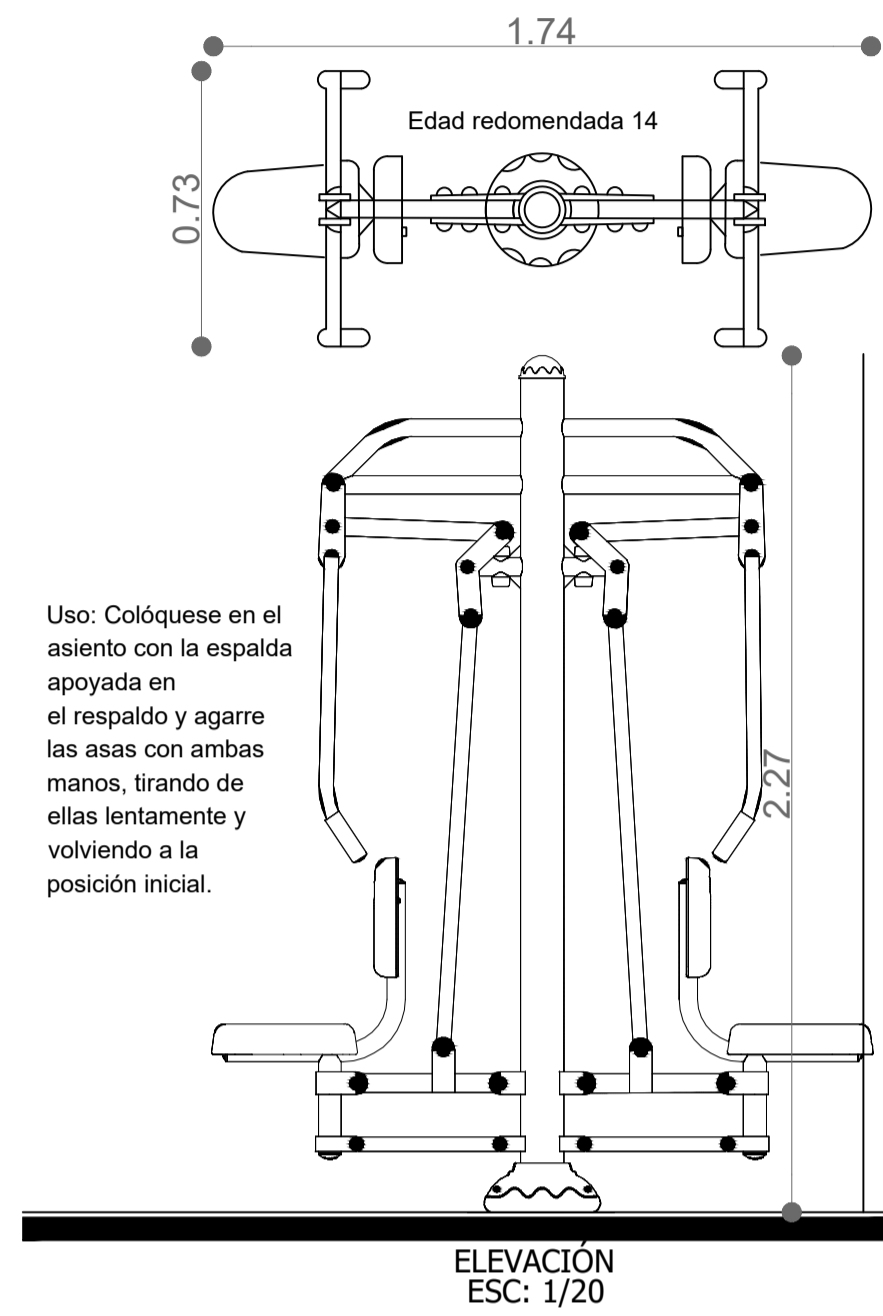

EJERCITADOR PECTORAL

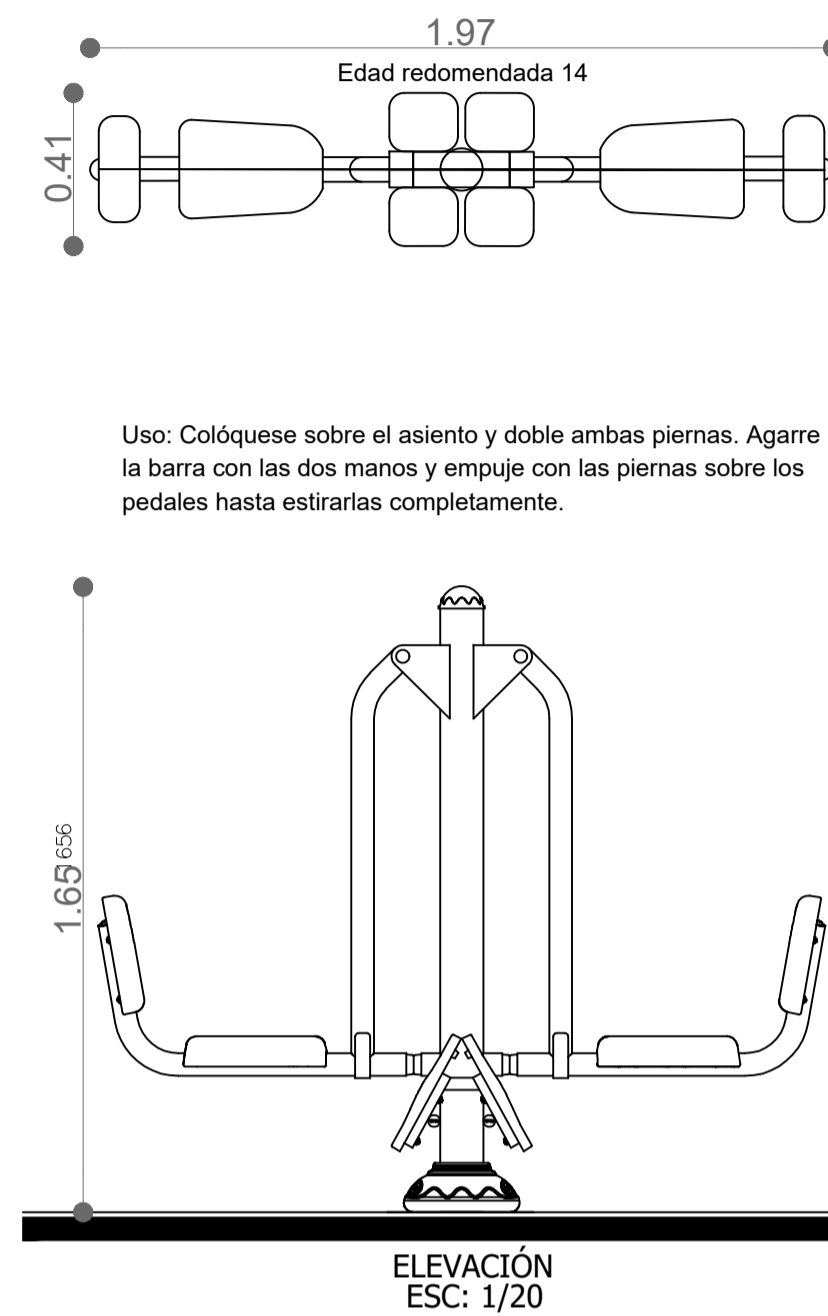

EJERCITADOR EXTENSIÓN

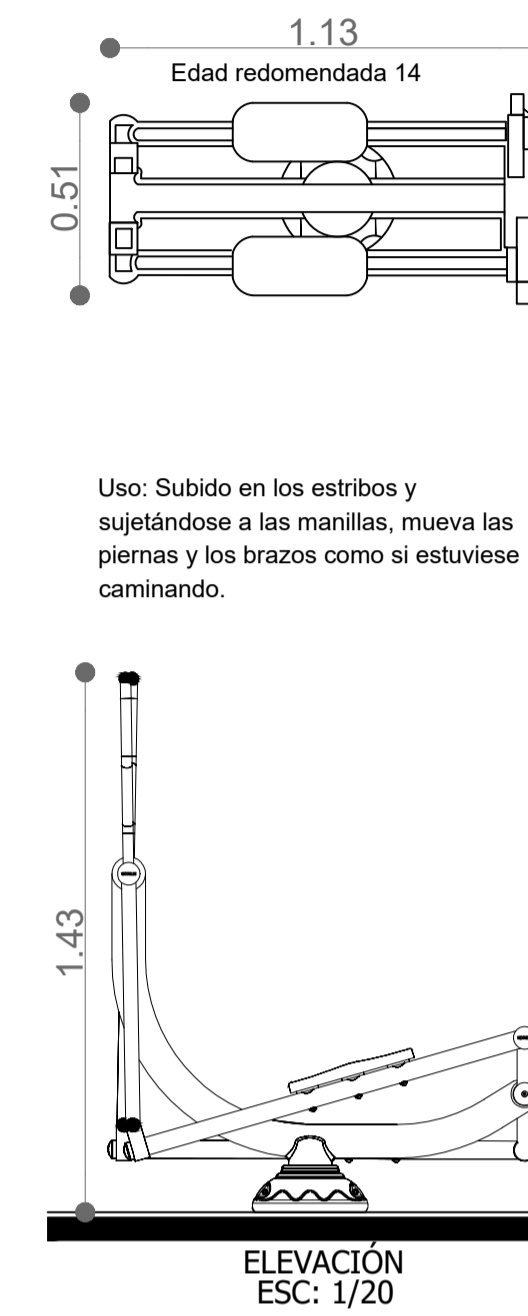

EJERCITADOR ESCALADORA

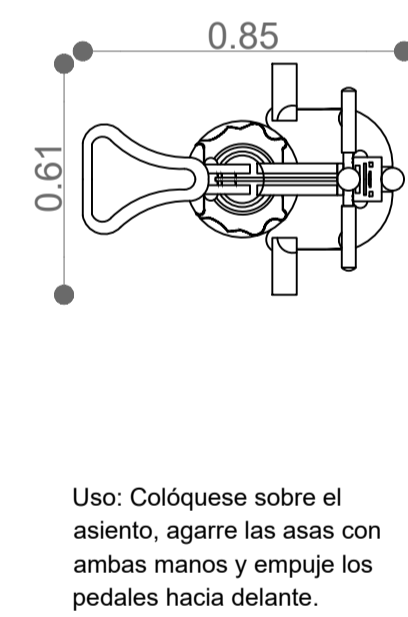

EJERCITADOR REMO

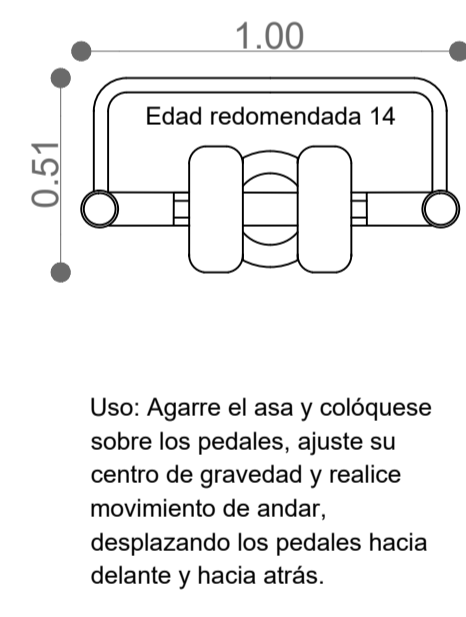

EJERCITADOR HOCKEY

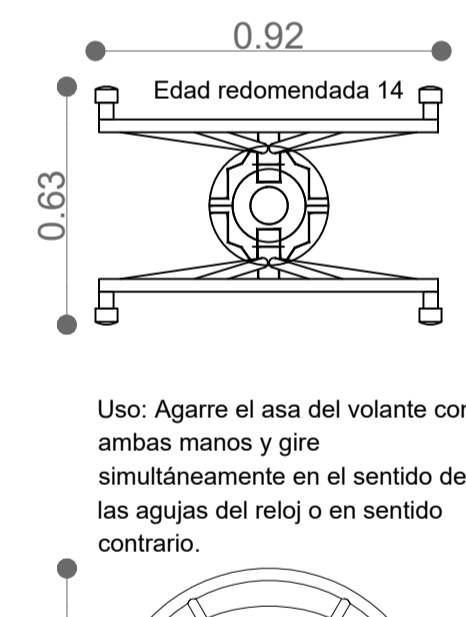

EJERCITADOR TIMON

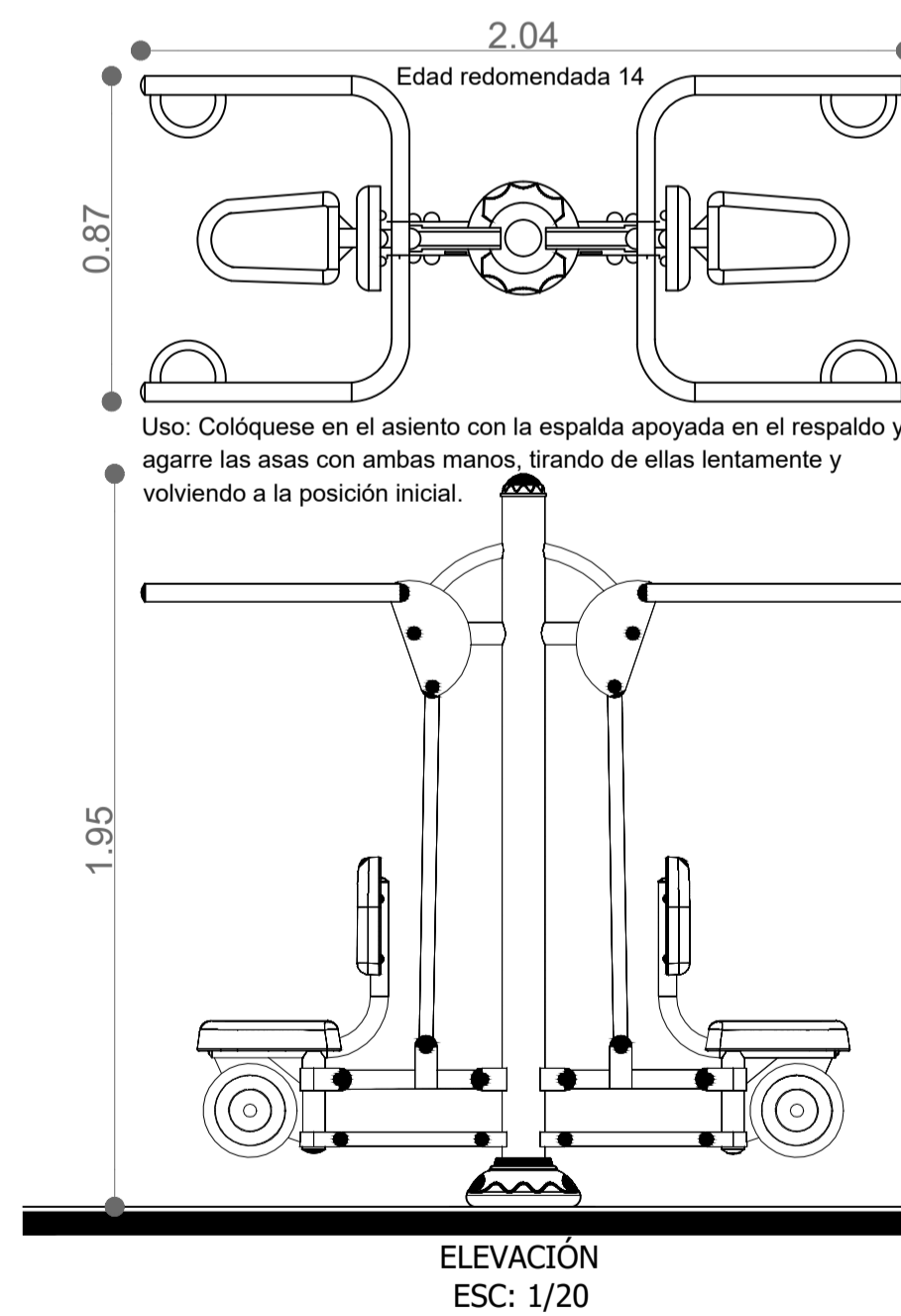

EJERCITADOR DORSALES

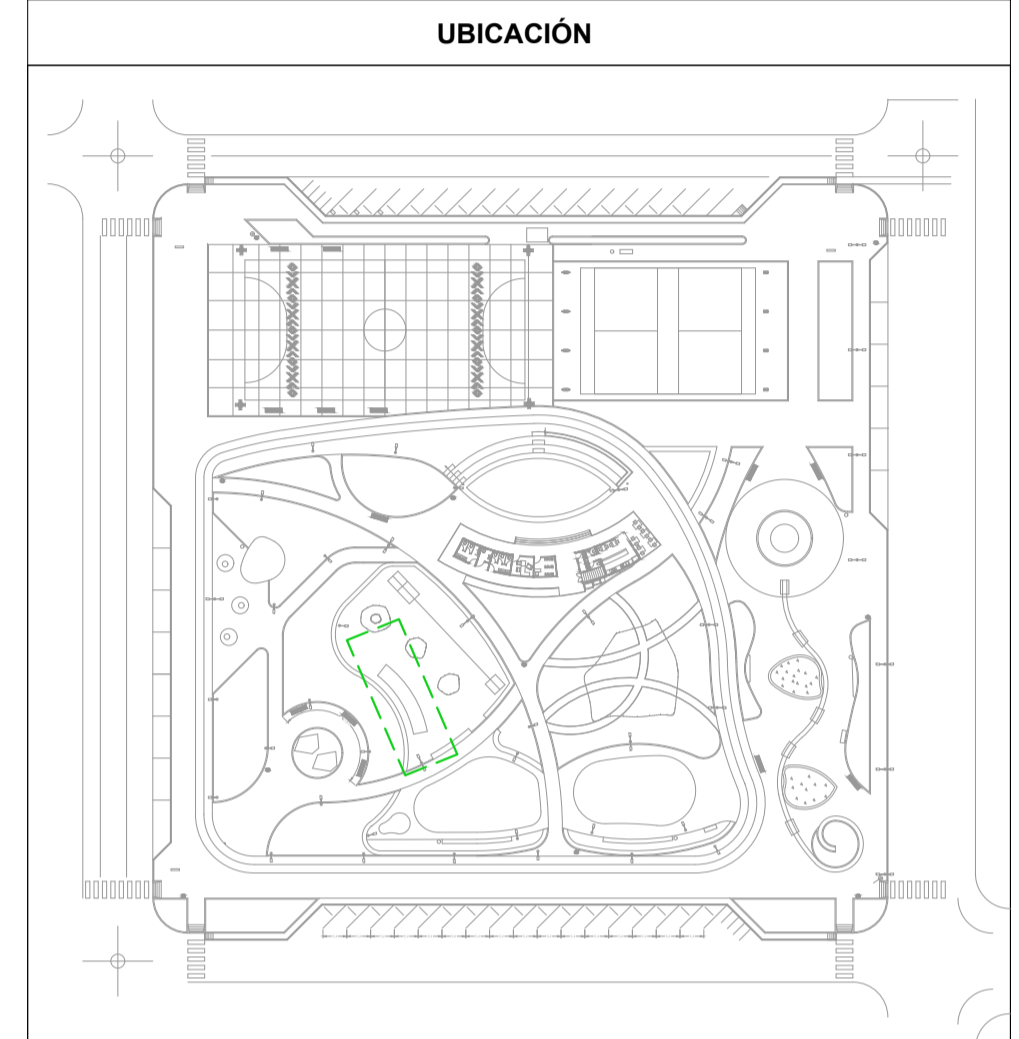
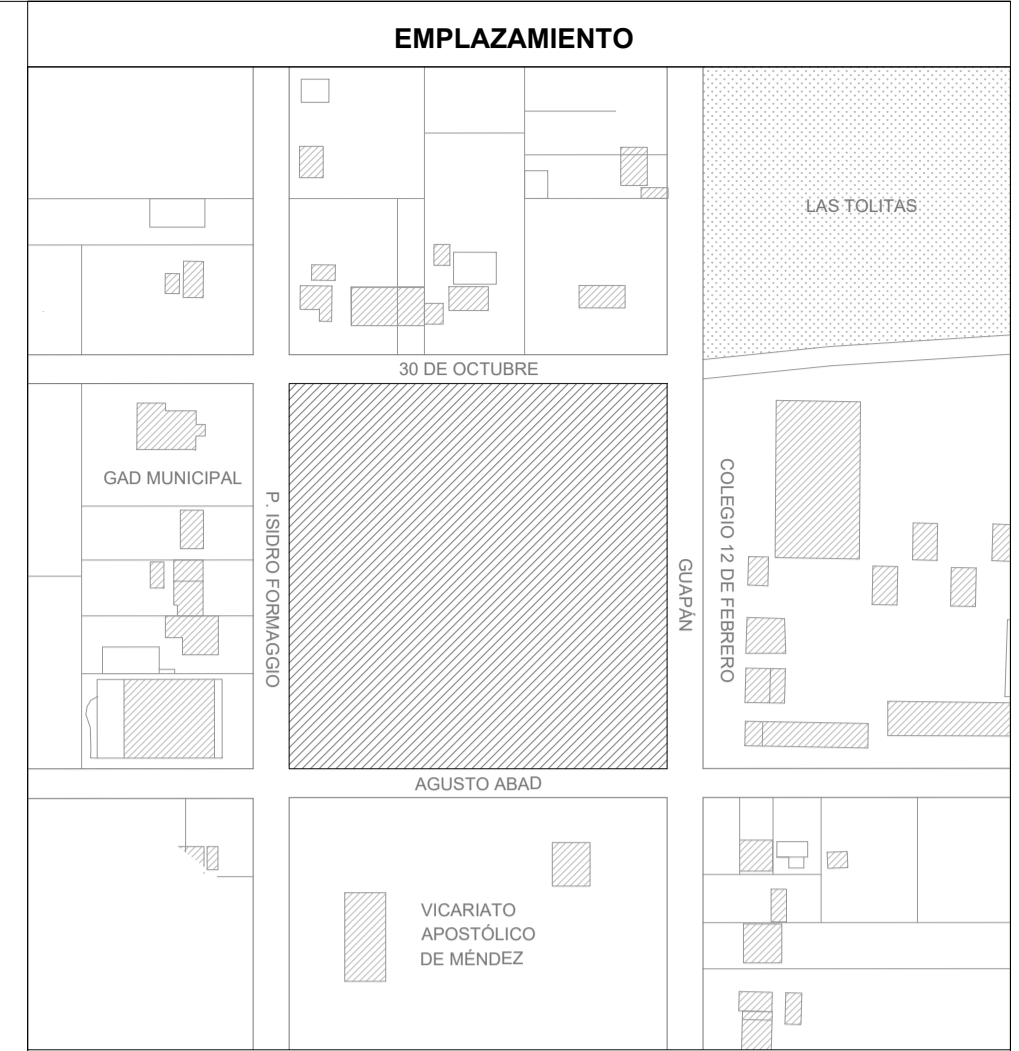

GAD MUNICIPAL DE PABLO SEXTO
DIRECCIÓN DE PLANIFICACIÓN TERRITORIAL E INSTITUCIONAL
PROYECTO: PARQUE CENTRAL DE PABLO SEXTO

| | | |
|---|---|--|
| SELLO: | CONTENIDO: JUEGOS BIOSALUDABLES | |
| DIBUJO: | DISÑO Y APROBACIÓN: | APROBACIÓN: |
| ARO. CHRISTOPHER OUSIRURUBAY TÉCNICO DE ORDENAMIENTO SEMESCOT 1029-2020-2225306 | ARO. EDDY BUJUZARAY ONCE DIRECTOR DE PLANIFICACIÓN SEMESCOT 1001-14-1375438 | ING. MGR. LENIN VERDUGO G. ALCALDE GADAPSE SEMESCOT 1010-13-746297 |
| ESCALA: ESC: S/N | FECHA: Noviembre - 2022 | LÁMINA: AR-014 / AR-019 |